



# MAXEON 3 SOLAR PANEL

415-430 W | Up to 22.7% Efficient



Ideal for residential applications



Ideal for commercial applications



White backsheet, black frame

## More Lifetime Energy

Designed to maximise energy generation through leading efficiency, enhanced performance in high temperatures, and higher energy conversion in low-light conditions like mornings, evenings and cloudy days.

## Uncompromising Durability

Engineered to power through all types of weather conditions with crack-resistant cells and reinforced connections that protect against fatigue and corrosion, to an electrical architecture that mitigates the impact of shade and prevents hot-spot formation.



## Superior Sustainability

Clean ingredients, responsible manufacturing, and lasting energy production for 40 years make Maxeon panels the most sustainable choice in solar.



## The Industry's Longest Warranty

Maxeon panels are covered by a 40-year warranty<sup>1</sup> backed by extensive third-party testing and field data from more than 33 million panels deployed worldwide.

Product and power coverage	40 Years
Year 1 minimum warranted output	98.0%
Maximum annual degradation	0.25%



Learn more about the SPR-MAX3-XXX-R  
[maxeon.com](http://maxeon.com)



**MAXEON 3 POWER: 415–430 W | EFFICIENCY: Up to 22.7%**

Electrical Data			
	SPR-MAX3-430-R	SPR-MAX3-425-R	SPR-MAX3-415-R
Nominal Power (P <sub>nom</sub> ) <sup>2</sup>	430 W	425 W	415 W
Power Tolerance	+5/0%	+5/0%	+5/0%
Panel Efficiency	22.7%	22.4%	21.9%
Rated Voltage (V <sub>mpp</sub> )	35.1 V	34.9 V	34.5 V
Rated Current (I <sub>mpp</sub> )	12.25 A	12.18 A	12.03 A
Open-Circuit Voltage (V <sub>oc</sub> )	40.7 V	40.7 V	40.6 V
Short-Circuit Current (I <sub>sc</sub> )	13.15 A	13.13 A	13.10 A
Max. System Voltage	1000 V UL & 1000 V IEC		
Maximum Series Fuse	25 A		
Power Temp Coef.	-0.27% / °C		
Voltage Temp Coef.	-0.236% / °C		
Current Temp Coef.	0.058% / °C		

Operating Condition And Mechanical Data	
Temperature	-40°F to +185°F (-40°C to +85°C)
Impact Resistance	1 inch (25 mm) diameter hail at 52 mph (23 m/s)
Solar Cells	112 Monocrystalline Maxeon Gen 3
Tempered Glass	High-transmission tempered anti-reflective
Junction Box	IP-68, Stäubli (MC4), 2 bypass diodes
Weight	46.7 lbs (21.2 kg)
Max. Load <sup>6</sup>	Wind: 50 psf, 2400 Pa back Snow: 112 psf, 5400 Pa front HVHZ: <sup>7</sup> 112 psf, 5400 Pa front and back
Frame	Class 1 black anodized (highest AAMA rating)

Certifications and Compliance	
Standard Tests <sup>3</sup>	UL 61730, IEC 61215, IEC 61730
Quality Management Certs	ISO 9001:2015, ISO 14001:2015
Ammonia Test	IEC 62716
Desert Test	IEC 60068-2-68, MIL-STD-810G
Salt Spray Test	IEC 61701 (maximum severity)
PID Test	1000 V: IEC 62804
Available Listings	UL, TUV
IFLI Declare Label	First solar panel labeled for ingredient transparency and LBC-compliance. <sup>4</sup>
Cradle to Cradle Certified™ Silver	First solar panel line certified for material health, water stewardship, material reutilization, renewable energy & carbon management, and social fairness. <sup>5</sup>
Green Building Certification Contribution	Panels can contribute additional points toward LEED and BREEAM certifications.
EHS Compliance	RoHS, ISO 45001:2018, Recycle Scheme, REACH SVHC-163

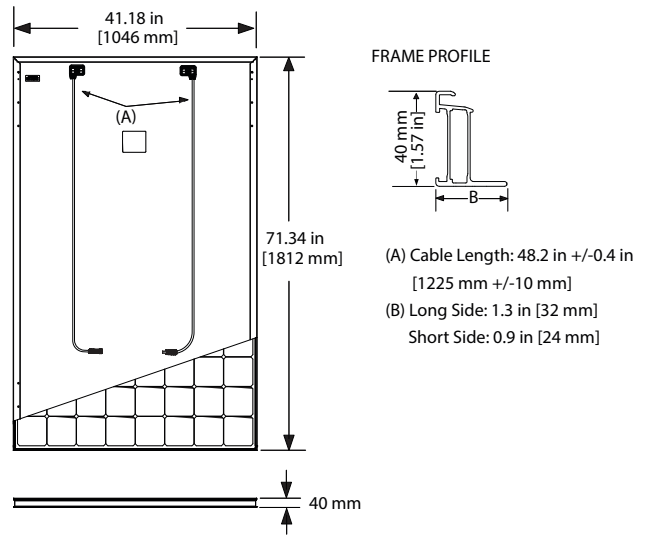

Please read the safety and installation instructions. Visit [www.maxeon.com/us/InstallGuideUL](http://www.maxeon.com/us/InstallGuideUL). Paper version can be requested through [techsupport.ROW@maxeon.com](mailto:techsupport.ROW@maxeon.com).



1 40-year warranty is not available in all countries or all installations and requires registration, otherwise our 25-year warranty applies. Service availability varies by country and installation provider. When PV Modules are used in a system over 500 kW or on a ground-mount application, such as a tracker or carport, the Product and Power Warranty Terms shall each be limited to 25 years unless written approval is provided by Maxeon and the PV Modules are digitally registered.

2 Standard Test Conditions (1000 W/m<sup>2</sup> irradiance, AM 1.5, 25° C). NREL calibration Standard: SOMS current, LACCS FF and Voltage.

3 Type 2 fire rating per UL 61730, Class C fire rating per IEC 61730.

4 Maxeon DC panels first received the International Living Future Institute Declare Label in 2016.

5 Maxeon DC panels are Cradle to Cradle Certified™ Silver -

[www.c2ccertified.org/products/scorecard/maxeon\\_solar\\_panels\\_-\\_maxeon\\_corporation](http://www.c2ccertified.org/products/scorecard/maxeon_solar_panels_-_maxeon_corporation). Cradle to Cradle Certified™ is a certification mark licensed by the Cradle to Cradle Products Innovation Institute.

6 As per IEC 61215-2016 tested and certified.

7 Florida High Velocity Hurricane Zone (HVHZ) or equivalent US building codes. Please refer to the Safety and Installation guide for additional details.

Made in Philippines (Cells)

Assembled in Mexico (Module)

Specifications included in this datasheet are subject to change without notice.

©2023 Maxeon Solar Technologies. All Rights Reserved.

View warranty, patent and trademark information at [maxeon.com/legal](http://maxeon.com/legal).



545907 REV C / LTR\_US  
Publication Date: May 2023