

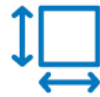

400–425 W Residential AC Module

SunPower® Maxeon® Technology

Built specifically for use with the SunPower Equinox™ system, the only fully integrated solution designed, engineered and warranted by one manufacturer.



Highest Power Density Available.

SunPower's new Maxeon® Gen 5 cell is 65% larger than prior generations, delivering the most powerful cell and highest-efficiency panel in residential solar. The result is more power per square meter than any commercially available solar.

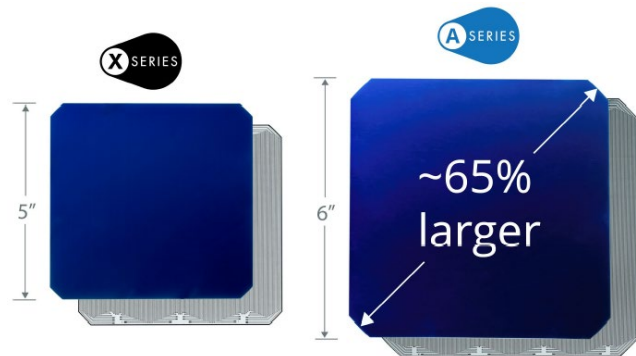

Fundamentally Different. And Better.

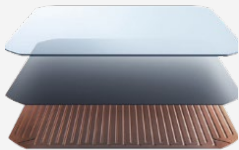

SunPower® Maxeon® Technology

- Most powerful cell in home solar ²
- Delivers unmatched reliability ³
- Patented solid metal foundation prevents breakage and corrosion



Factory-integrated Microinverter (MI)

- Highest-power integrated AC module in solar
- 60% lighter than prior SunPower MIs
- Engineered and calibrated by SunPower for SunPower AC modules



Highest Lifetime Energy and Savings.

Designed to deliver 60% more energy over 25 years in real-world conditions like partial shade and high temperatures.¹

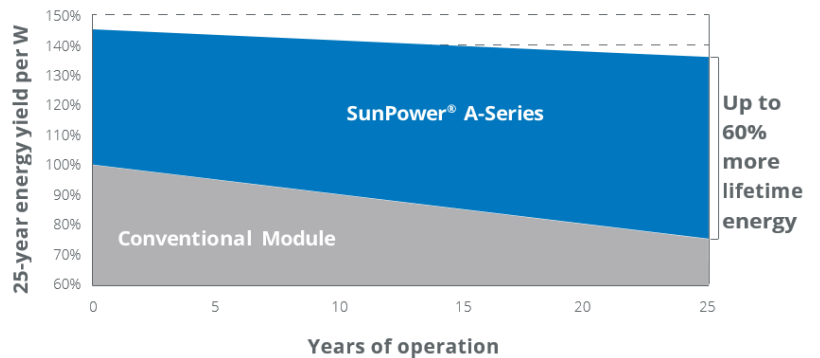

Best Reliability. Best Warranty.

With more than 25 million modules deployed around the world, SunPower technology is proven to last. That's why we stand behind our module and microinverter with the industry's best 25-year Combined Power and Product Warranty, including the highest Power Warranty in solar.



A-Series: A425 | A415 | A400 SunPower® Residential AC Module

| AC Electrical Data | |
|---|----------------------|
| Inverter Model: SPWR-A4 | @240 VAC |
| Peak Output Power | 366 VA |
| Max. Continuous Output Power | 349 VA |
| Nom. (L-L) Voltage/Range ² (V) | 240 / 211–264 |
| Max. Continuous Output Current (A) | 1.45 |
| Max. Units per 20 A (L-L) Branch Circuit ³ | 11 |
| CEC Weighted Efficiency | 97.0% |
| Nom. Frequency | 60 Hz |
| Extended Frequency Range | 47–68 Hz |
| AC Short Circuit Fault Current Over 3 Cycles | 5.8 A rms |
| Overvoltage Class AC Port | III |
| AC Port Backfeed Current | 18 mA |
| Power Factor Setting | 1.0 |
| Power Factor (adjustable) | 0.7 lead. / 0.7 lag. |

| DC Power Data | | | |
|---|---|---------------|---------------|
| | SPR-A425-G-AC | SPR-A415-G-AC | SPR-A400-G-AC |
| Nom. Power ⁵ (P _{nom}) | 425 W | 415 W | 400 W |
| Power Tol. | +5/-0% | +5/-0% | +5/-0% |
| Module Efficiency | 22.8 | 22.3 | 21.5 |
| Temp. Coef. (Power) | -0.29%/°C | | |
| Shade Tol. | Integrated module-level max. power point tracking | | |

| Tested Operating Conditions | |
|-----------------------------|--|
| Operating Temp. | -40°F to +140°F (-40°C to +60°C) |
| Max. Ambient Temp. | 122°F (50°C) |
| Max. Load | Wind: 62 psf, 3000 Pa, 305 kg/m ² front & back Snow: 125 psf, 6000 Pa, 611 kg/m ² front |
| Impact Resistance | 1 inch (25 mm) diameter hail at 52 mph (23 m/s) |

| Mechanical Data | |
|---------------------------------|---|
| Solar Cells | 66 Monocrystalline Maxeon Gen 5 |
| Front Glass | High-transmission tempered glass with anti-reflective coating |
| Environmental Rating | Outdoor rated |
| Frame | Class 1 black anodized (highest AAMA rating) |
| Weight | 46.5 lbs (21.1 kg) |
| Recommended Max. Module Spacing | 1.3 in. (33 mm) |

1 SunPower 415 W, 22.2% efficient, compared to a Conventional Panel on same-sized arrays (260 W, 16% efficient, approx. 1.6 m²), 7.9% more energy per watt (based on PVsyst pan files for avg. US climate), 0.5%/yr slower degradation rate (Jordan, et. al. "Robust PV Degradation Methodology and Application." PVSC 2018).
 2 Based on search of datasheet values from websites of top 10 manufacturers per IHS, as of January 2019.
 3 #1 rank in "Fraunhofer PV Durability Initiative for Solar Modules: Part 3." PVTech Power Magazine, 2015. Campeau, Z. et al. "SunPower Module Degradation Rate," SunPower white paper, 2013.
 4 Factory set to 1547a-2014 default settings. CA Rule 21 default settings profile set during commissioning. See the Equinox Installation Guide #518101 for more information.
 5 Standard Test Conditions (1000 W/m² irradiance, AM 1.5, 25°C). NREL calibration standard: SOMS current, LACCS FF and voltage. All DC voltage is fully contained within the module.
 6 This product is UL Listed as PVRSE and conforms with NEC 2014 and NEC 2017 690.12; and C22.1-2015 Rule 64-218 Rapid Shutdown of PV Systems, for AC and DC conductors; when installed according to manufacturer's instructions.

See www.sunpower.com/facts for more reference information.
 For more details, see extended datasheet www.sunpower.com/datasheets Specifications included in this datasheet are subject to change without notice.
 ©2019 SunPower Corporation. All Rights Reserved. SUNPOWER, the SUNPOWER logo and MAXEON are registered trademarks of SunPower Corporation in the U.S. and other countries as well. 1-800-SUNPOWER.

| Warranties, Certifications, and Compliance | |
|--|---|
| Warranties | <ul style="list-style-type: none"> • 25-year limited power warranty • 25-year limited product warranty |
| Certifications and Compliance | <ul style="list-style-type: none"> • UL 1703 • UL 1741 / IEEE-1547 • UL 1741 AC Module (Type 2 fire rated) • UL 62109-1 / IEC 62109-2 • FCC Part 15 Class B • ICES-0003 Class B • CAN/CSA-C22.2 NO. 107.1-01 • CA Rule 21 (UL 1741 SA)⁴ (includes Volt/Var and Reactive Power Priority) • UL Listed PV Rapid Shutdown Equipment⁶ <p>Enables installation in accordance with:</p> <ul style="list-style-type: none"> • NEC 690.6 (AC module) • NEC 690.12 Rapid Shutdown (inside and outside the array) • NEC 690.15 AC Connectors, 690.33(A)-(E)(1) <p>When used with InvisiMount racking and InvisiMount accessories (UL 2703):</p> <ul style="list-style-type: none"> • Module grounding and bonding through InvisiMount • Class A fire rated <p>When used with AC module Q Cables and accessories (UL 6703 and UL 2238)⁶:</p> <ul style="list-style-type: none"> • Rated for load break disconnect |
| PID Test | Potential-induced degradation free |

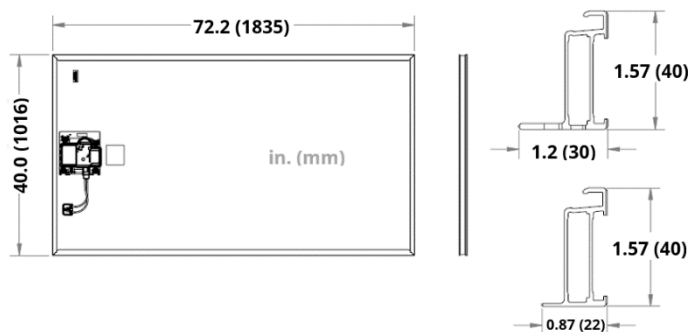

UL LISTED
 AC MODULE
 GRID SUPPORT UTILITY
 INTERACTIVE
 PV RAPID SHUTDOWN
 EQUIPMENT
 E478330
 Module Fire Performance: Type 2
 Please read the Safety and Installation Instructions 532628 for additional details.

SUNPOWER®

532618 RevA