



Sanctuary™ Energy Storage System

Manual

8kW Hybrid Inverter / Charger and 13.5kWh Lithium Battery





READ THIS MANUAL IN ITS ENTIRETY BEFORE OPERATING THE UNIT.

This unit provides safe, silent, and renewable electric power. It is very important to carefully read this user manual before using the product. Keep this manual for future reference. It can also be found at <https://lionenergy.com/pages/sanctuary>

Carefully read and strictly comply with all safety directives. Otherwise, personal bodily injury or death may result.

Follow these directives for safe use:

- **Caution: Only qualified personnel/technicians can install and service this device with or without a battery.**
- Before using the inverter, read the instructions and warning signs for the Lithium battery and all relevant sections in the instruction manual.
- Do not disassemble the inverter. If you need maintenance or repair, take it to a professional service center. Improper reassembly may result in electric shock or fire and will void the warranty.
- To reduce risk of electric shock, disconnect all wires before performing maintenance or cleaning. Turning off the unit alone does not reduce this risk.
- For optimum performance of the inverter, follow the specifications when selecting the appropriate cable size. It is very important to correctly operate the inverter.
- Be very cautious when using metal tools near the battery. Dropping a tool on or in the unit may cause a spark or short circuit in the battery or other electrical parts, and may even cause an explosion.
- Strictly follow the installation procedure when disconnecting the AC or DC terminals. Refer to the Installation section of this manual for details.
- **Grounding instructions:** Connect the inverter to a permanent, grounded wiring system. Be sure to comply with local requirements and regulations when installing the inverter.
- Do not connect to the mains when there is a short circuit in the DC input.
- This system includes heavy equipment. Use lifting assistance during installation.

Table of Contents

4	Product Introduction & Features
5	Basic System Architecture
6	Inverter Overview
7-9	Parts
10	Installation Location
11	Bracket Installation
12-13	Battery Connection
14-19	Wiring The Inverter
	<ul style="list-style-type: none">• 15 AC Connections• 16 CT Connections• 17-19 PV Connections
20-21	Fault Information & Processing
22-24	Technical Specifications
25-26	Warranty Certificate

Product Introduction

This is a multi-functional Energy Storage System (ESS), which combines the functions of an inverter, solar charger, battery charger and lithium battery to offer uninterruptible power supply. The system is commissioned and monitored by way of app, available on phone and PC.

Product Features

The Sanctuary Energy Storage System offers an impressive array of features:

- 240V split-phase pure sine wave inverter, 208V three-phase pure sine wave inverter.
- Self-consumption mode and grid-tied net metering capable.
- Programmable supply priority for either the battery or the grid.
- Programmable multiple operation modes: On grid, Off grid, Time of use (peak shaving), and UPS (Uninterrupted Power Supply at 5 ms).
- Configurable battery charging current / voltage.
- Configurable AC / Solar charging priority.
- Compatible with main power or generator power.
- Overload, excessive temperature, and short circuit protection.
- Smart battery charger design for optimized battery performance.
- Prevents excessive power overflow to the grid.
- The Lion Sanctuary is operated with an app from your smart device or computer. The app allows for customized settings and provides necessary data.
- Maximum 160A battery discharge.
- Maximum PV input 10.4kW.
- Customizable power output settings to account for **time of use** rate structures to maximize ROI.
- The 13.5kWh batteries are made from high-grade Lithium Iron Phosphate (LiFePO4) cells for long life and in-home safety.

Basic System Architecture

This figure depicts the basic application of the Lion Sanctuary System. Power is fed into the system from the power grid, solar power array or generator to have a complete running system.

The Lion Sanctuary Energy Storage System can provide power for residences, including appliances, communication equipment, lights and other devices.

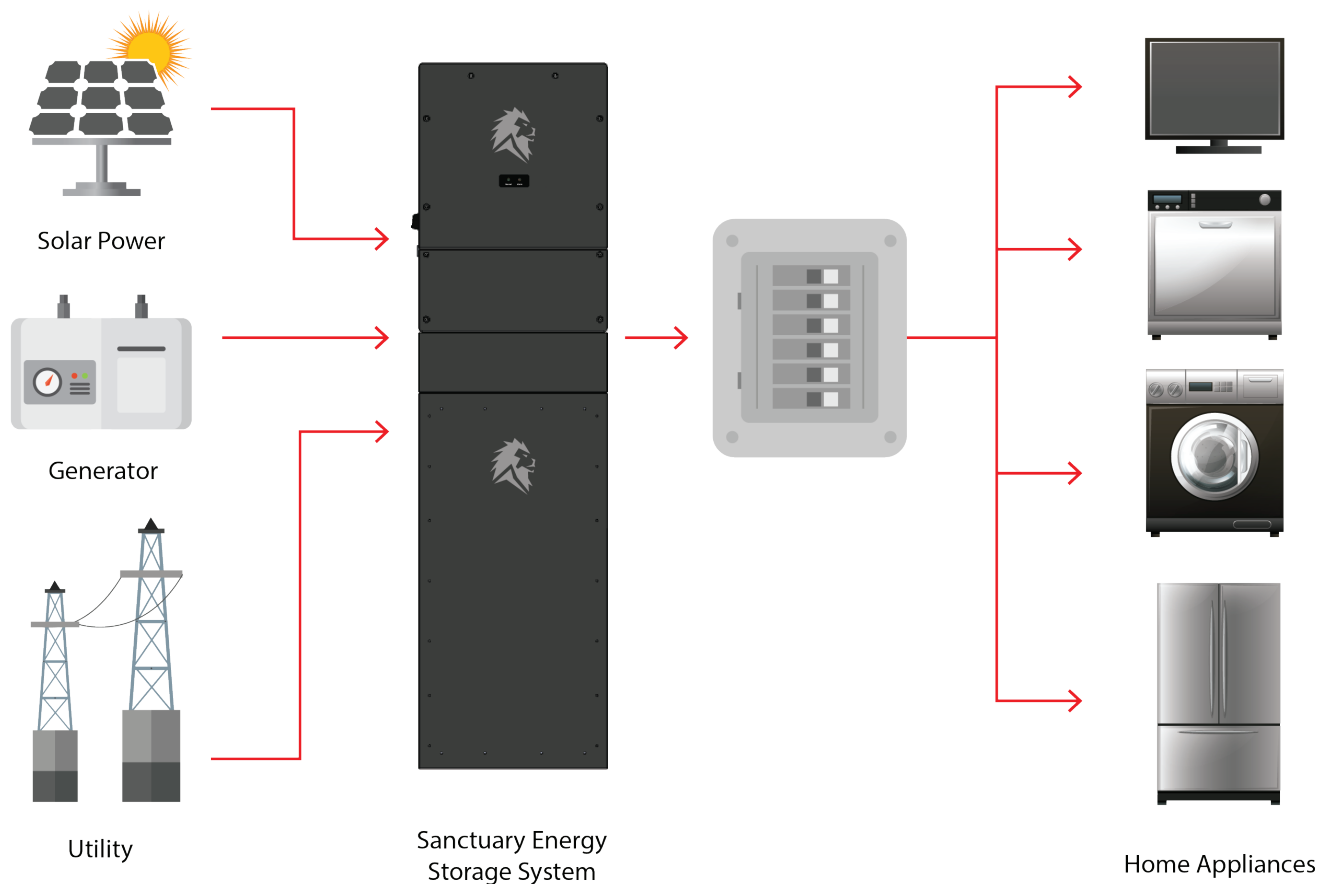

Other architectures

Consult with Lion Energy for other possible system architectures to accommodate your specific requirements.

Inverter Overview

The Lion Sanctuary is a powerful solar inverter/charger and energy storage system. It is used to harness the energy of the sun to provide power for your home, cabin, or houseboat. The diagram below identifies the parts for the inverter/charger components on the unit.

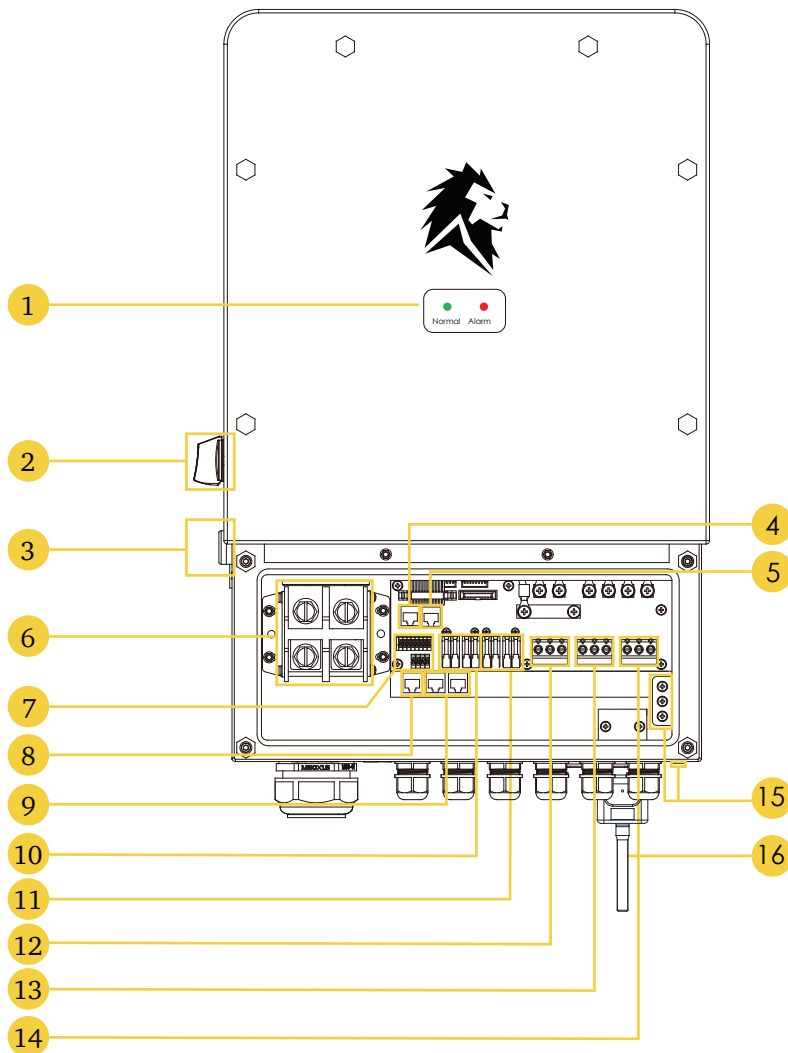

1	System Status Indicators	
2	High Voltage Disconnect	
3	On/Off System Shutdown	
4	RS485 Port Battery Communication Port	
5	CANbus Port	
6	Battery busbar terminal	
7	Advanced Function Ports	
1 & 2	Temp Sensor (not needed)	
3 & 4	CT Sensor Line 1	
5 & 6	CT Sensor Line 2	
7 & 8	Generator Start	
9 & 10	Generator Valve	
11 & 12	Rapid Shutdown 12V Supply	
	Automatic Transfer Switch	
8	Meter Port	
9	Parallel Inverter Communication Ports	
10	PV Input 1 (MPPT1)	
11	PV Input 2 (MPPT2)	
12	Grid AC Input	
13	Generator Input (Micro Inverter Input)	
14	Load AC Output	
15	Inverter Grounding Location	
16	Wifi Adapter	

Parts

Below is a list of all parts that are included with the Lion Sanctuary Energy Storage System. Installer may need to purchase additional hardware for custom mounting needs.

**Sanctuary 8kW
Inverter / Charger**



Quantity (by kit size)		
1 Battery	2 Battery	3 Battery
1	1	1

**13.5kWh
Lithium Battery**



Quantity (by kit size)		
1 Battery	2 Battery	3 Battery
1	2	3

Wi-Fi Adapter



Quantity (by kit size)		
1 Battery	2 Battery	3 Battery
1	1	1

Current Transformer



Quantity (by kit size)		
1 Battery	2 Battery	3 Battery
2	2	2

**AWG #2 Red & Black
Battery Cable Set (55")**



Quantity (by kit size)		
1 Battery	2 Battery	3 Battery
1	2	3

**AWG #2 Red & Black Busbar
to Inverter Cable Set (24")**



Quantity (by kit size)		
1 Battery	2 Battery	3 Battery
0	1	1

Parts

Battery COM Cable (24")



Quantity (by kit size)		
1 Battery	2 Battery	3 Battery
1	1	1

Battery COM Cable (60.5")



Quantity (by kit size)		
1 Battery	2 Battery	3 Battery
0	1	2

250A Busbar



Quantity (by kit size)		
1 Battery	2 Battery	3 Battery
0	2	2

Inverter Cleats



Quantity (by kit size)		
1 Battery	2 Battery	3 Battery
4	4	4

Battery COM Cable Splitter



Quantity (by kit size)		
1 Battery	2 Battery	3 Battery
0	1	1

Freestanding Wire Box



Quantity (by kit size)		
1 Battery	2 Battery	3 Battery
1	2	3

Parts

Wire Box Cover

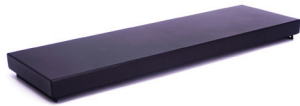

Quantity (by kit size)		
1 Battery	2 Battery	3 Battery
1	2	3

Inverter Wall Mount



Quantity (by kit size)		
1 Battery	2 Battery	3 Battery
2	2	2

Battery Wall Mount



Quantity (by kit size)		
1 Battery	2 Battery	3 Battery
1	2	3

Housing Bolts



Quantity (by kit size)		
1 Battery	2 Battery	3 Battery
4	8	12

Under Inverter Wiring Box



Quantity (by kit size)		
1 Battery	2 Battery	3 Battery
1	1	1

Optional



CAT5 Cable for parallel inverter installation

x 8



Concrete anchor bolts

Installation Location

Before installing the Lion Sanctuary System (inverter/charger and battery), consider the following when choosing a location for installation:

- Install the Sanctuary System in a climate controlled location, regulated temperature between 32° to 86° F. The Sanctuary System is suitable for use in residential dwelling units where permitted. This equipment meets the cell level performance criteria of UL 9540A.
- Be sure to keep other objects and surfaces away from the unit to permit adequate heat dissipation and provide space for wiring access. For proper air circulation, provide a clearance of at least 20 inches to the side and at least 12 inches above the unit.
- Note that the inverter, fans, and other internal components emit sound at 60dB (slightly louder than a standard computer fan).

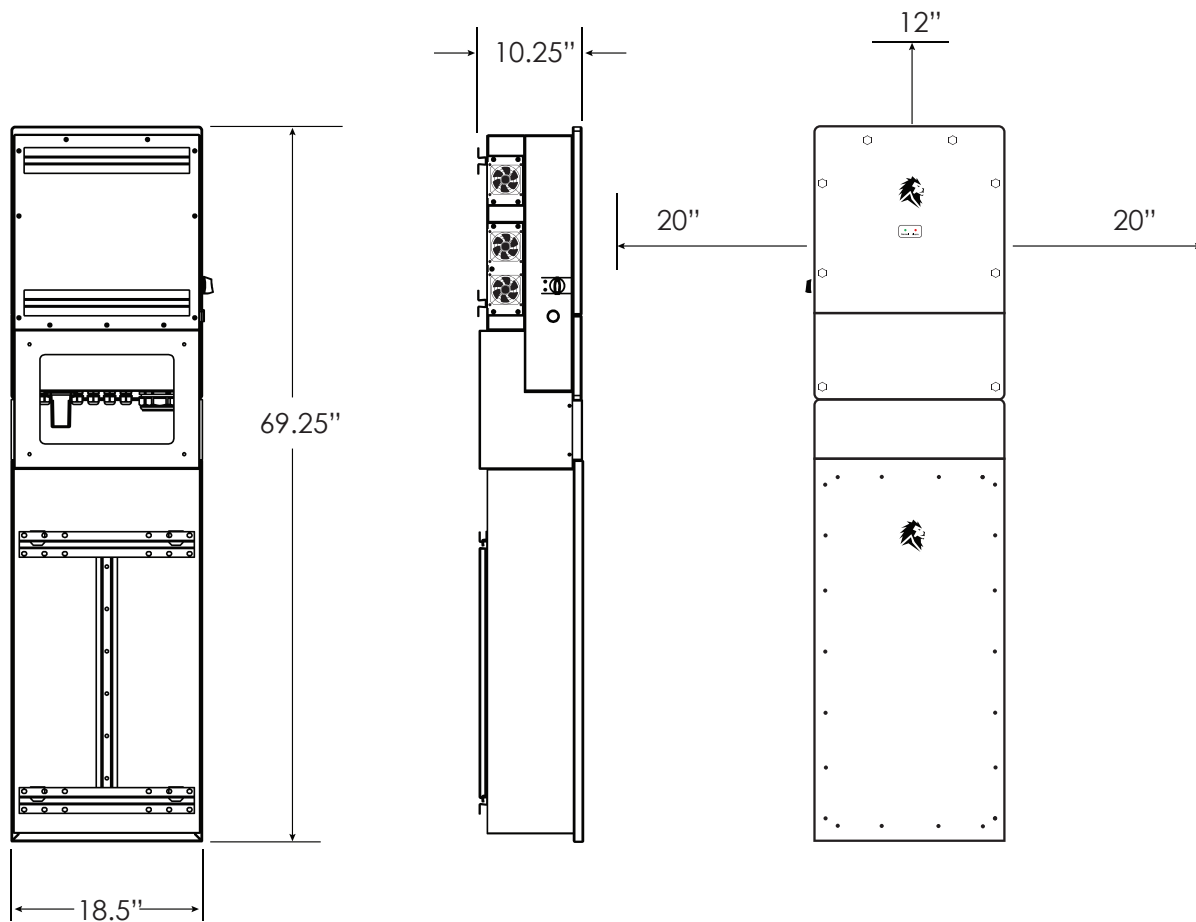

Bracket Installation

We recommend backing the installation location with plywood or other similar load bearing material for ease of installation and wire placement.

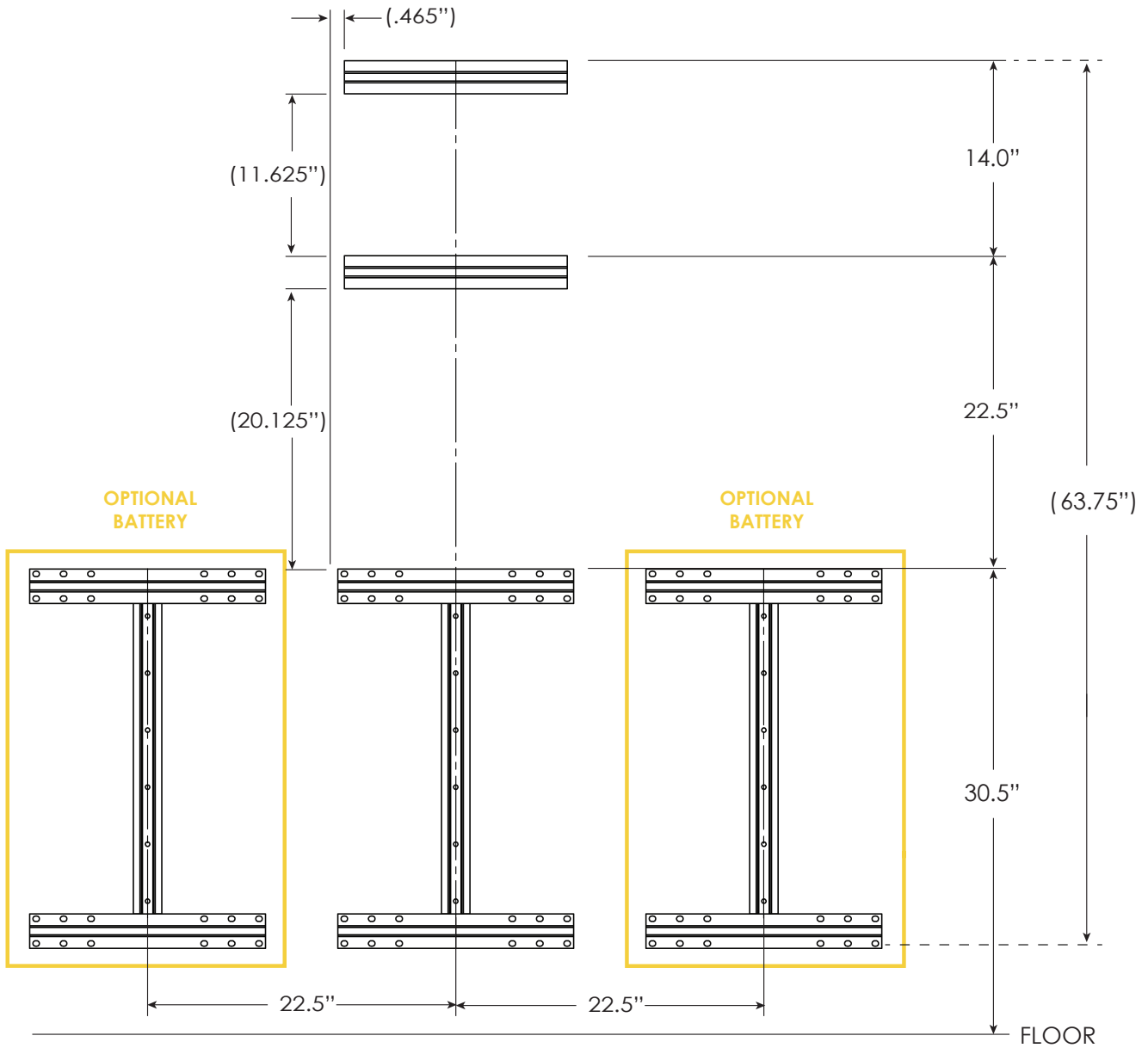

(YIELDS A RECOMMENDED 4" SPACING BETWEEN BATTERIES FOR EASE OF INSTALLATION)

MANUAL

A maximum of 36 panels can be connected. They must be connected properly as indicated below. To achieve proper configuration with solar panels, loads must be equalized between MPPTs and their inputs. Each MPPT has two sets of inputs that must be balanced as shown in the table to the right.

Total # of Panels	PV1 (A)	PV1 (B)	PV2 (A)	PV2 (B)
5	5	-	-	
6	6	-	-	
7	7	-	-	
8	8	-	-	
9	9	-	-	
10	5	5	-	
11	6	-	5	
12	6	6	-	
13	7	-	6	
14	7	7	-	
15	8	-	7	
16	8	8	-	
17	6	6	5	
18	6	6	6	
19	6	6	7	
20	7	7	6	
21	7	7	7	
22	7	7	8	
23	8	8	7	
24	8	8	8	
25	8	8	9	
26	7	7	6	6
28	7	7	7	7
30	8	8	7	7
32	8	8	8	8
34	9	9	9	8
36	9	9	9	9

Battery Connection

Before connecting any wires, remove the metal cover by removing four screws.

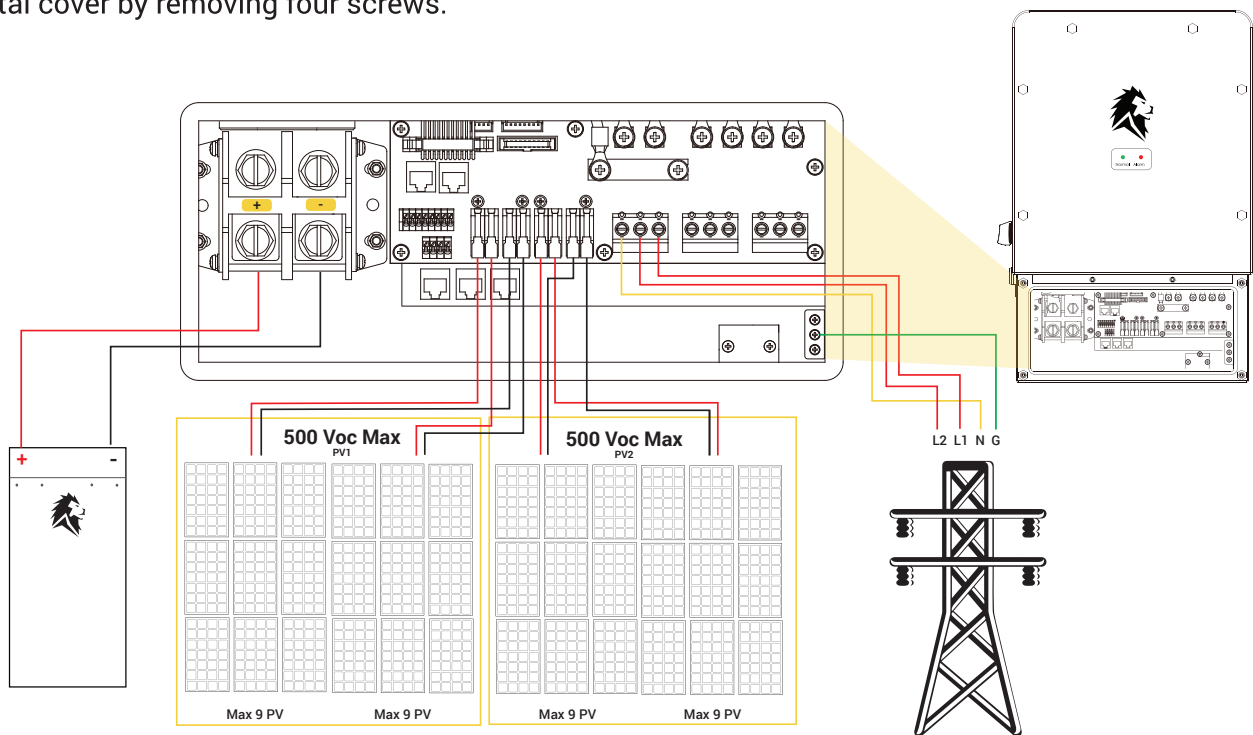

MANUAL

Model	Wire Size	Torque Value
8kW	2AWG	17.7 in-lbs



Professional wiring installation

All wiring must be performed by a professional electrician.



Suitable battery cable (included)

Only use the provided AWG #2 cables to connect the battery to the inverter.

Follow the steps below to connect the battery:

1. Use a suitable screwdriver to unscrew the bolts and insert the battery connectors, then fasten the bolt with the screwdriver. Be sure to tighten the bolts clockwise with a torque of 17.7 in-lbs.
2. Ensure that the polarity at both the battery and the inverter is correct.
3. Thread the wire through the weather resistant cable gland. Secure the wire connection, and attach the wires to the strain relief device with cable ties.



High voltage

There will be high voltage in the unit so be careful while installing the system.



Correctly connect positive and negative

Before making the final DC connection or closing the DC breaker / disconnect, be sure the positive (+) connects to positive (+) and negative (-) connects to negative (-).

Wiring the Inverter

Before connecting to AC input power source, install a separate AC breaker (70A or less) between the inverter and the AC input power source. It ensures that the inverter will readily disconnect during maintenance.

There are three terminal blocks with **IN** and **OUT** markings.



Use the correct cable

For system safety and efficient operation, it is very important to use an appropriate cable for the AC input connection. To reduce risk of injury, use the correct cable according to the information in the table below.

Model	Wire Size	Torque Value
8kW	6AWG	10.6 in-lbs



Disconnect the power source

Be sure to disconnect all power sources before attempting to wire the unit.



Potential damage to appliances

If a power shortage occurs and recovers in a short time, it may cause damage to the appliances you connect to the inverter. Appliances such as an air conditioner will need at least 2-3 minutes to restart because there must be sufficient time to balance the refrigerant gas in the system. To prevent such damage, check the air conditioner manual to learn if it is equipped with time-delay function. If not, this inverter may trigger an overload fault and terminate all output to protect your appliance. However, this may still cause internal damage to the air conditioner.

MANUAL

Refer to the figures below and follow these steps to connect the AC input and output:

1. Before connecting the AC input and output, be sure to first disconnect all power sources, **including switching the DC disconnect to "Off"**.
2. Remove a 0.4" length of insulation sleeve, unscrew the bolts, and insert the AC input wires through the cable glands according to the polarities indicated on the terminal block. Then tighten the terminal screws. Ensure that the connection is complete.
3. Insert the AC output wires through the cable glands according to the polarities indicated on the terminal block, then tighten the terminal screws. Be sure to connect the corresponding N wires and PE (Ground) wires to related terminals. Make sure all connections are tightened to 10.6 in-lbs.

AC Connections

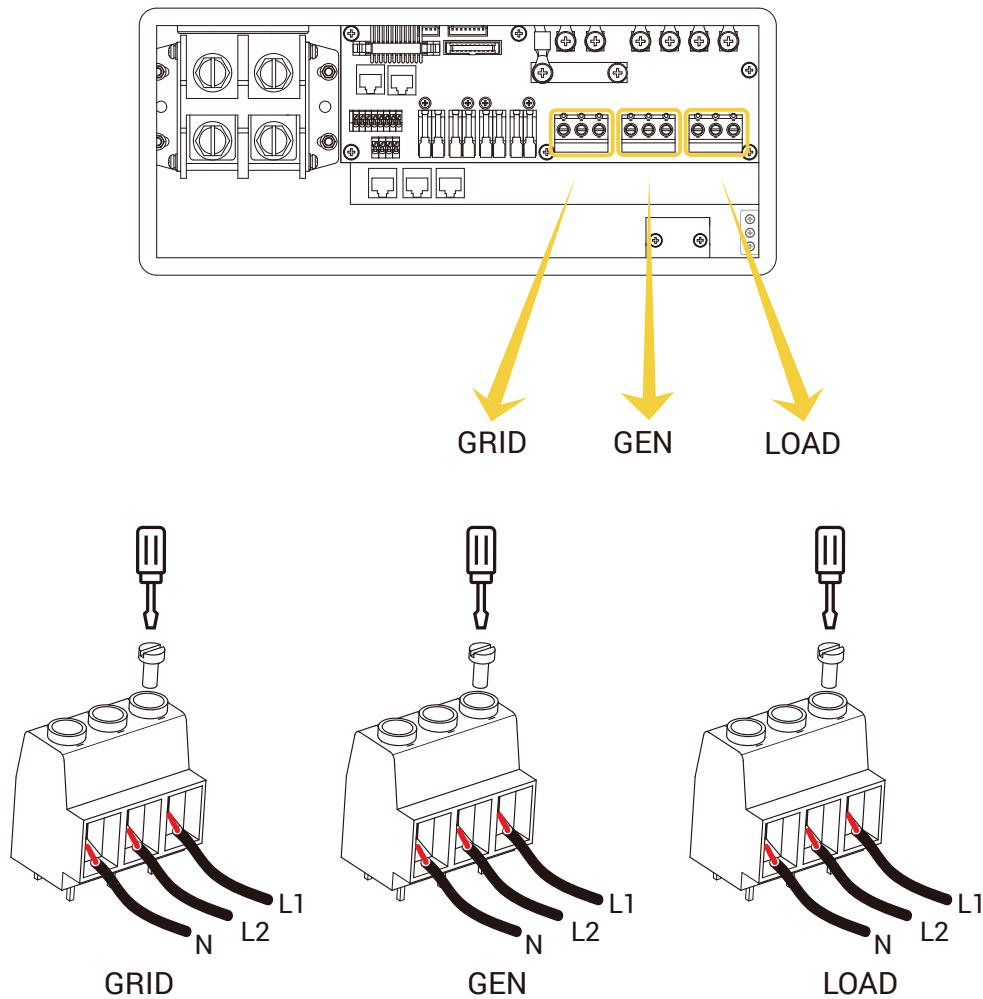

CT Connections

The diagram below is the Current Transformer (CT) hookup to allow for the system work load setting "zero export to CT".

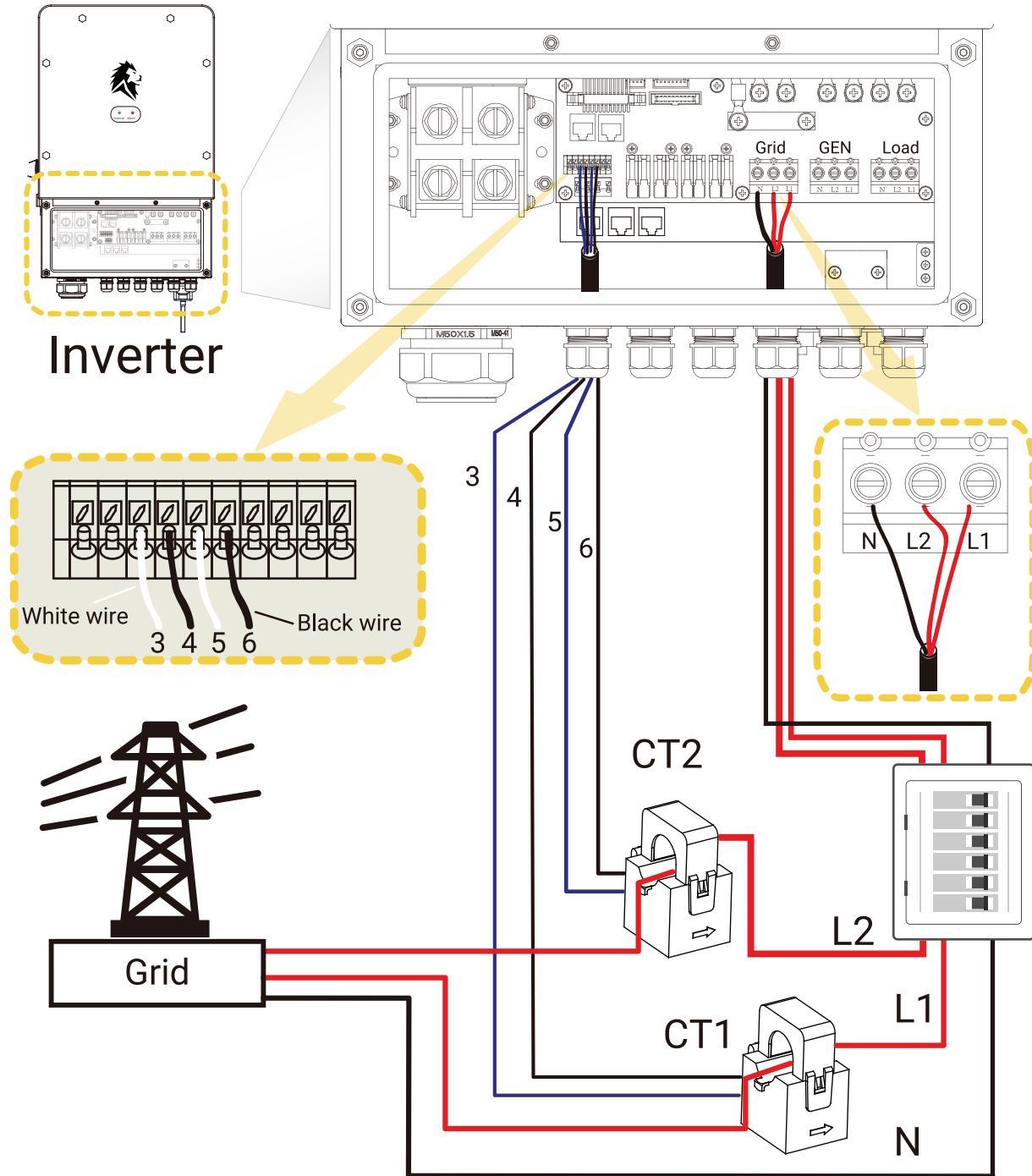

PV Connection

It is important for system safety and efficient operation to use the appropriate cables for the PV module connections. To reduce risk of injury, use the recommended cable size given in the table below.

Model	Wire Size	Torque Value
8kW	1x12AWG	10.6 in-lbs



Avoid PV modules with current leakage

To avoid any malfunction, do not connect any PV modules with possible current leakage to the inverter. For example, grounded PV modules will cause current leakage to the inverter. When using PV modules, be sure there is no negative grounding.



Use surge protection

Use a PV junction box that provides surge protection. Otherwise, damage from a lightning strike to a PV module may result in damage to the inverter.

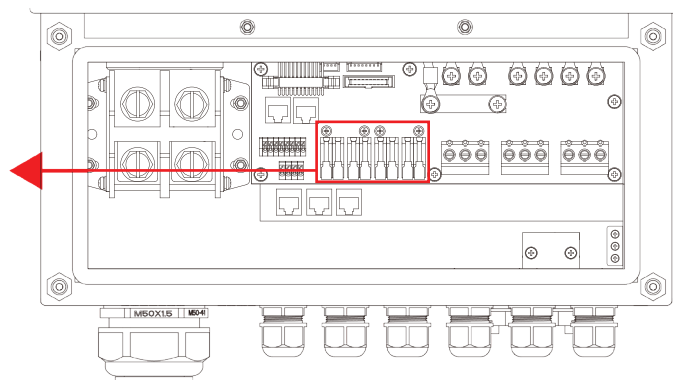
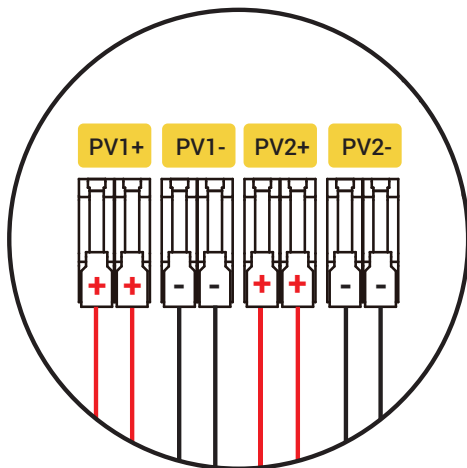

Solar Input Wiring

PV Module Selection

When selecting suitable PV modules, be sure to consider the following (see table below):

Inverter	Sanctuary 8kW	Model 50170167
Maximum Peak Power Watts (Wp)	10,400 Wp	
Maximum Open Circuit Voltage (Voc)	500 Voc	
Maximum Power Voltage (Vmp)	125 - 425 VDC	

PV Module Wire Connection

Follow the steps below to connect the PV module:

1. Remove 0.4" of the insulation sleeve for positive and negative conductors.
2. Verify correct polarity of all wire connections for the PV modules and PV input connectors. Insert the wires through the cable glands and connect the positive pole (+) of the connection wire to the positive pole (+) of the PV input connector. Connect the negative pole (-) of the connection wire to the negative pole (-) of the PV input connector. Close the switch and ensure the wires are secure.

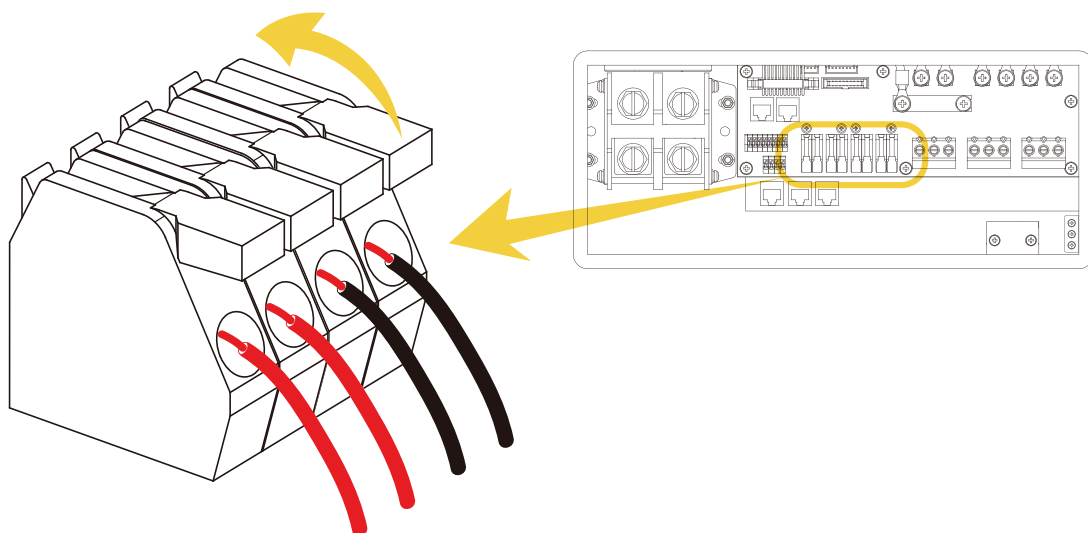

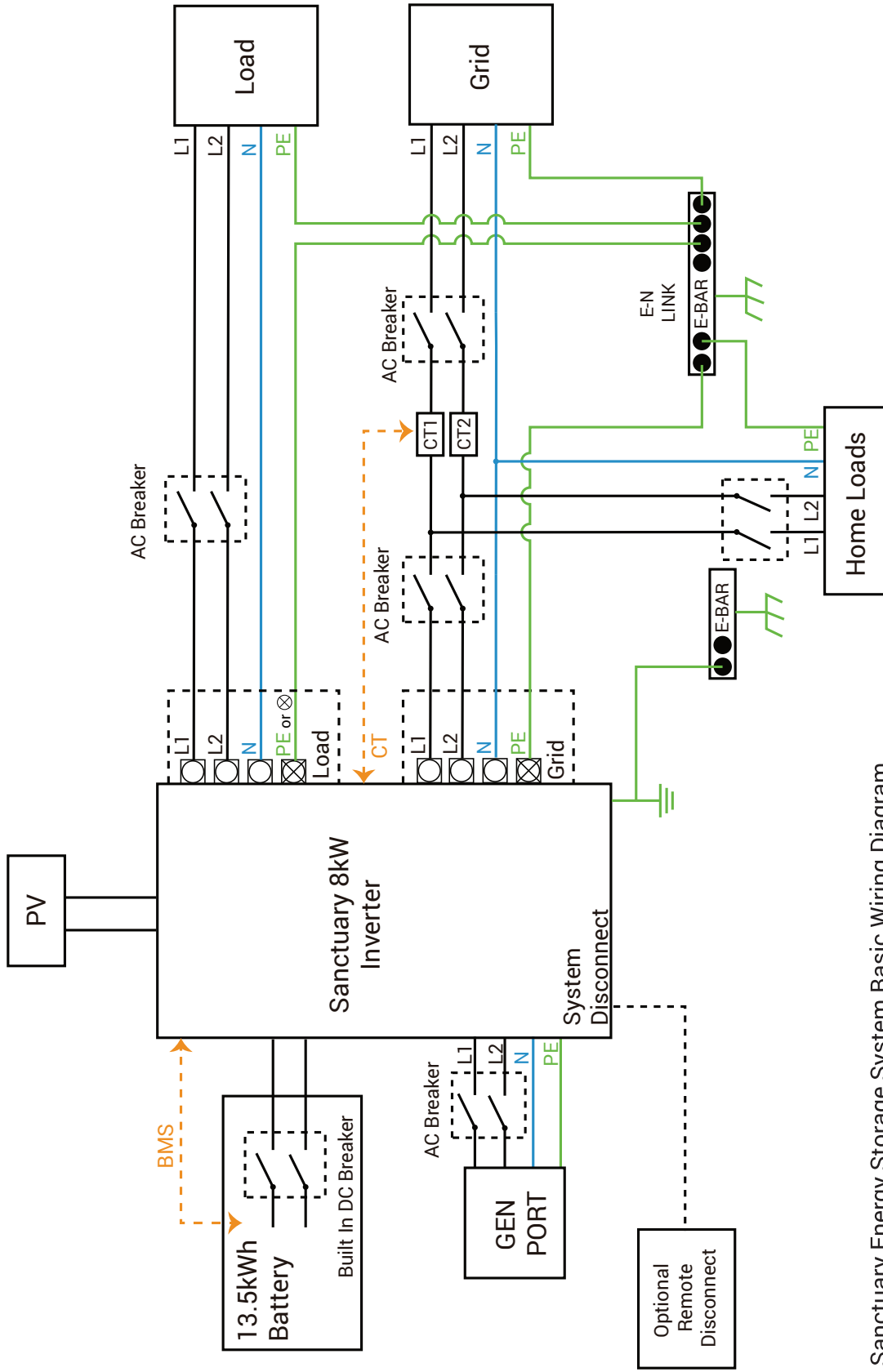

Sanctuary Energy Storage System Basic Wiring Diagram

Fault Information and Processing

The table below lists the possible fault codes that might occur if the inverter malfunctions.

Error Code	Description	Solutions
F08	GFDI relay fault	<ol style="list-style-type: none"> 1. When the inverter is in Split phase (120/240Vac) or a three-phase system (120/208Vac), the backup load port N line needs to connect to ground.
F13	Working mode change	<ol style="list-style-type: none"> 1. When the grid type and frequency are changed, it will report F13. 2. When the battery mode is changed to “No battery” mode, it will report F13. 3. Under normal working conditions F13 will disappear automatically.
F18	AC over current fault	<ol style="list-style-type: none"> 1. Ensure the backup load power and the common load power are within range.
F20	DC over current fault	<ol style="list-style-type: none"> 1. Verify PV module and battery connections. 2. When in off-grid mode, a large inverter surge may cause an F20 fault. Reduce the load that is causing the surge.
F22	Tz EmergStop fault	Contact Lion Energy
F23	AC current leak fault	<ol style="list-style-type: none"> 1. Verify PV side cable ground connection. 2. Restart the system 2~3 times to clear the fault memory.
F24	DC insulation impedance fault	<ol style="list-style-type: none"> 1. Verify all connections to the PV and the inverter are secure. 2. Verify the inverter to ground connection is secure.
F26	DC busbar inbalance fault	<ol style="list-style-type: none"> 1. Upon initial power up, this fault may occur and will usually reset within a few minutes. 2. In split phase mode, if the load on L1 and L2 are significantly unbalanced, it will report the F26. Consider rebalancing the load. 3. Restart the system 2~3 times to clear the fault memory.
F29	Parallel CANBus fault	<ol style="list-style-type: none"> 1. With multiple systems in parallel mode, check the parallel communication cable connection and inverter communication address setting. 2. During the parallel system startup period, inverters will report F29. When all inverters are in “Normal” status, the fault will disappear automatically.

MANUAL

Error Code	Description	Solutions
F34	AC over current fault	1. Verify the backup load is connected and is within allowed power range.
F35	No AC grid fault	1. Verify grid power is available and is within operating range. 2. Verify the grid connection is secure. 3. Verify the switch/breaker between the inverter and grid is on.
F41	Parallel system stop fault	1. Verify all inverters are in “Normal” status.
F42	AC line low voltage fault	1. Verify the AC voltage is within operating range and the grid side AC cables are securely connected.
F47	AC high frequency fault	1. Verify the frequency is within operating range and the AC cables are securely connected.
F48	AC low frequency fault	1. Verify the frequency is within operating range and the AC cables are securely connected.
F56	DC busbar low voltage fault	1. Verify the battery voltage is within operating range. 2. If the battery voltage is too low, charge using the PV or grid.
F58	BMS communication fault	1. Ensure the battery communication cable is securely connected to both the battery and the RS485 port on the inverter.
F63	ARC fault	1. Verify the PV module connections are secure, then clear the fault.
F64	Heat sink high temperature fault	1. Verify the unit is installed in a climate controlled environment with a maintained temperature between 32°F and 86°F. 2. Ensure there is at least a 20” clearance to the sides and 12” clearance above the inverter. 3. Turn off the inverter for 10 mins and restart.

If you are unable to clear the fault, restart the system. If the fault still shows, contact Lion Energy for assistance.

Technical Specifications

Lion Energy Sanctuary Energy Storage System (ESS)

Model #99990514 - 13.5kWh Sanctuary ESS

Model #99990516 - 27.0kWh Sanctuary ESS

Model #99990517 - 40.5kWh Sanctuary ESS

Major System Components

Model #50170132 - Sanctuary 13.5kWh Battery

Model #50170167 - Sanctuary 8kW Inverter

Model #50170132 - Sanctuary 13.5kWh Battery

Voltage Range	40 - 55.6 VDC
Capacity	13.8kWh
Parallelable Capacity	41.4kWh MAX
Quantity	3 MAX
Charging Temperature Range / Current	32° to 86° F / 150A
Discharging Temperature Range / Current	-4° to 86° F / 160A
Weight	270 lbs.
Dimensions	39.75" H x 18.5" W x 9.75" D
Compliance	UL1973, UL9540, UL9540A

Model #50170167 - Sanctuary 8kW Inverter

Product Type	Hybrid Inverter / Charger
Enclosure	IP65
Ambient Temperature	32° to 86° F
Weight	70 lbs.
Dimensions	26.8" H x 18.5" W x 9.3" D
Compliance	UL1741, UL9540, UL1699

Charge Mode

Battery Voltage	48VDC (40V - 60V)
Battery Current	190ADC Max
AC Input Voltage	208/240VAC (120VAC)
AC Input Frequency	60Hz
AC Input Rated Current	33.4AAC
Max AC Input Current	38.3AAC Max
Max AC Input Power	8.8kW
PV Input Voltage	370VDC (100VDC - 500VDC)
MPPT Input Range	125VDC - 425VDC
PV Input Current	22ADC + 22ADC
Max PV Input Power	10.4kW
Max PV ISC	25ADC + 25ADC

On-Grid Mode

AC Output Voltage	208 / 240VAC (120VAC)
AC Output Frequency	60Hz
AC Output Rated Current	33.4AAC
Max AC Output Current	38.3AAC Max
Max AC Output Power	8.8kW
AC Output Rated Power	8kW
Max Continuous AC Pass through	70AAC
AC Output Power Factor	0.8 leading to 0.8 lagging
Max AC ISC	145AAC
Battery Discharge Voltage	40V - 60VDC
Battery Discharge Current	190ADC Max
Battery Discharge Power	8.8kW

Off-Grid Mode

AC Output Voltage	208 / 240VAC (120VAC)
AC Output Frequency	60Hz
AC Output Rated Current	33.4AAC
AC Output Rated Power	8kW
Peak Output Power	16kW 10 Seconds
Battery discharge Voltage	40V - 60VDC
Max Discharge Current	190ADC Max
PV Input Voltage	370VDC (100VDC-500VDC)
MPPT Input Range	125VDC - 425VDC
PV Input Current	22ADC + 22ADC
Max PV Input Power	10.4kW
Max PV ISC	25ADC + 25ADC

Install in a climate controlled environment to maintain a temperature between 32° and 86° F.

This Grid support Interactive Inverter complies with ULSTD.1741, UL1741 SA, CPUC RULE21, SRD-UL-1741-SA-V1.1, IEEE1547-2003, FCC 15 class-B, UL1699B Arc-Fault Circuit-protection Type 1.



Caution:

- High Voltage.
- Keep the equipment well ventilated.
- The capacitors store hazardous energy.



Lion Sanctuary Energy Storage System

The Lion Sanctuary warranty is for 10 years (can be upgraded to 25 years). The 10 year limited warranty (“Warranty”) is against manufacturing defects and workmanship; the battery is rated for 6,000 cycles to 90% depth of discharge. The warranty begins from the date the Sanctuary System is installed. System must be connected to the internet and lion energy must be granted monitoring access in order to qualify for warranty.

If the unit needs to be repaired or replaced, follow these steps:

1. Customer contacts the Installer to verify there is an issue with the unit.
2. Installer contacts Lion Energy to discuss the issues and Lion Energy will determine if the unit will be repaired or replaced.
3. Installer repairs the unit or if the unit is to be replaced, Lion Energy will ship the unit to the Installer.
4. Installer replaces the unit and ships the replaced unit to Lion Energy for proper recycling.

The warranty does not include:

- Damage during transportation of equipment.
- Damage caused by incorrect installation or commissioning.
- Damage caused by failure to comply with operation instructions, installation instructions, or maintenance instructions.
- Damage caused by attempts to modify, alter, or repair products.
- Damage caused by incorrect use or operation.
- Damage caused by insufficient ventilation of equipment.
- Damage caused by failure to comply with applicable safety standards or regulations.
- Damage caused by natural disasters or force majeure (such as floods, lightning, over voltage, storms, and fires).
- Any external scratches will not affect the basic operation of the product. Any external scratches, stains or natural mechanical wear does not represent a defect in the product.

Limitation of Liability

THIS LIMITED WARRANTY IS THE ENTIRE WARRANTY AND ANY OTHER EXPRESSED OR IMPLIED WARRANTIES ARE NOT APPLICABLE. THIS WARRANTY EXCLUDES ANY LIABILITY FOR PRODUCT NOT BEING AVAILABLE FOR USE OR LOST REVENUES OR PROFITS. Lion Energy only warrants the product, not the power service or external electrical equipment or any services provided by another party. This manual provides information, specification, and usage instructions. All statements, information, and suggestions within in this manual do not constitute any express or implied warranty.

Recycling

Return the Sanctuary System to Lion Energy for proper disposal.

Warranty Certificate



Thanks for choosing the Lion Sanctuary Lithium Energy Storage System. It is a high-quality, hybrid inverter and energy storage unit that can be expandable. It comes with a standard 10 year warranty and can be upgraded to a 25 year warranty.

To activate the warranty, fill out all the information below and return it to Lion Energy. All the information is required. You can scan it or send a photo of this page to Warranty@LionEnergy.com

Warranty Information

Inverter Serial Number (on Side Panel): _____

Battery #1 Serial Number (on Side Panel): _____

Battery #2 Serial Number (on Side Panel): _____

Battery #3 Serial Number (on Side Panel): _____

Installation Date: _____

Physical Address of Installation: _____

Location in the home of Installation: _____

Name of Installation Company and Installer: _____

Phone Number of Installation Company: _____

Number of Solar Panels at Location: _____

Brand of Solar Panels: _____

Solar Panel Model #: _____

VOC # (On Panels): _____ PVM # (On Panels): _____ Total PV on Site: _____

Check Applicable Warranty: Standard 10 Year Upgraded 25 Year



385.375.8191
Monday - Friday
9:00 AM - 5:00 PM MST



735 S. Auto Mall Drive Suite 200
American Fork, Utah
84003



warranty@lionenergy.com
www.lionenergy.com
[@lionenergy](https://twitter.com/lionenergy)



LIONENERGY™



385.375.8191
Monday - Friday
9:00 AM - 5:00 PM MST



735 S. Auto Mall Drive Suite 200
American Fork, Utah
84003



info@lionenergy.com
www.lionenergy.com
[@lionenergy](https://www.lionenergy.com)